

EtherCAT®

EST-556

EtherCAT Stepper Drive



© 2018 shenzhen ECON Technology Co.,Ltd. Version 1.0

Add:2F,BuildingB,Jintai,Industrial,Park,HangchengAvenue,GushuVillage,XixiangStreet,Bao'anArea,ShenzhenCity,GuangdongProvince,China

E-mail:enquiry@hybridservo.com

technical01@hybridservo.com

All rights reserved

[Please read this manual carefully before use to avoid damage the drive]

Contents

<i>Part 1:EST-556 Hardware Manual</i>	5
1 Descriptions.....	5
2 Features	5
3 Applications	5
4.1 Electrical Specifications	5
4.2 Operating Environment	6
5 Mechanical Specifications	6
6 Connectors and Pin Assignment	7
6.1 Control signals connector.....	7
6.2 Power and Motor	8
6.3 EtherCAT Communication Port.....	9
7 PA settings (DIP Switch Settings)	9
7.1 Current Table(dynamic current)	10
7.2 Standstill current setting	10
7.3 Motor direction setting	10
7.3 Smoothing filter time setting.....	10
8 Stepper Motors	10
8.1 Nema23 stepper motor.....	11
8.2 Nema14 stepper motor.....	11
9 Wiring Diagrams	11
9.1 Interface.....	11
9.2 Diagram.....	12
10 Protection Indications.....	12
11 Frequently Asked Questions.....	13
Problem Symptoms and Possible Causes.....	13
12 Warranty	14
Exclusions	14
Obtaining Warranty Service	14
Warranty Limitations	14
<i>Part 2 :EST-556EtherCATCommunication Protocol Specification</i>	15
1. Introduction	15
2. Operation mode	15
2.1 Profile position mode(PP)	15
2.1.1 Related objects.....	16
2.1.2 Controlword and Status word	16
2.1.3Typical motion mode of bit 5 at PP mode	16
2.1.4 The bit 8,10.12-15 of status word	17
2.2 Profile velocity mode(PV).....	18
2.3Cyclic synchronous position modemode(CSP)	18
2.3.1 Related objects.....	18
2.4 Homing mode(HM).....	19
3. Input and output.....	21

3.1	Input configuration	21
3.2	Output configuration	22
3.3	Related node ID	23
3.4	Motor rotation direction setting	23
3.5	Pulse/Revolution setting	23
4.	Parameters.....	24
4.1	Parameter saving.....	24
4.2	Parameter reset.....	24
4.3	Parameters list.....	24
5.	Basic Information Of EtherCAT	28
5.1	EtherCATData Frame Structure	28
5.2	Synchronous Mode.....	28
5.2.1	Random running mode.....	28
5.2.2	Distributed clock synchronization mode	29
5.2.3	EtherCAT state machine	29
5.3	COE	30
5.3.1	Service data object (SDO)	30
5.3.2	SDO protocol and message format	30
5.3.3	SuspendSDO transmission.....	32
5.4	processing data object	33
5.4.1	PDO mapping	33
5.4.2	PDO dynamicalmapping.....	34
5.4.3	The difference of PDO and SDO.....	35
Contact us:	35

EtherCAT :

EtherCAT (Ethernet for Control Automation Technology) is open network communication using real-time Ethernet between masters and slaves developed by Beckhoff Automation GmbH, Germany.

This User Manual of EST-556 Included:

Part 1: EST-556 hardware manual

This part for hardware, function description, parameter configuration, etc.

Part 2 :EST-556 EtherCAT communication protocol specification

This part for EtherCAT communication protocol.

Notice!

Read this manual carefully before any assembling and using. Incorrect handling of products in this manual can result in injury and damage to persons and machinery. Strictly adhere to the technical information regarding installation requirements.

This manual is not for use or disclosure outside of ECON technology except under permission. All rights are reserved. No part of this manual shall be reproduced, stored in retrieval form, or transmitted by any means, electronic, mechanical, photocopying, recording, or otherwise without approval from ECON technology. While every precaution has been taken in the preparation of the book, ECON technology assumes no responsibility for errors or omissions. Neither is any liability assumed for damages resulting from the use of the information contained herein.

This document is proprietary information of ECON technology that is furnished for customer use ONLY. Information in this document is subject to change without notice and does not represent a commitment on the part of ECON technology. Therefore, information contained in this manual may be updated from time-to-time due to product improvements, etc., and may not conform in every respect to former issues.

Part 1: EST-556 Hardware Manual

1 Descriptions

EST-556 is Econ technology's new EtherCAT hybrid servo driver ,which adopt the latest floating-point 32-bit MCU digital processing technology ,the advanced vector control technology drive the motor with low heating ,low noise and extra smoothness. The user can set any ID address within 1-255 and any current value under the rated current, it can be matched with different of size motors(from Nema23/Nema24) to applied for variable applications. the drive can auto-tuning for matching the motor when power up ,which can automatically generate optimal operating parameters for different motors to maximize the performance of the motor

2 Features

- ✧ New floating point 32bit MCU technology
- ✧ And Auto Tune after power up
- ✧ 3 channels opto-coupler isolation output
- ✧ Advanced vector control technology
- ✧ 5 channels opto-coupler isolation input,2 of them are high speed opto-coupler isolation input
- ✧ Communication Frequency up to 100MHz
- ✧ DIPs can set 127 IPs or automatic allocate IP
- ✧ Current setting range 1.0-5.6A(peak),the default is 4.2A
- ✧ Smooth movement and extra low noise
- ✧ The matched motor can be nema23,nema24

3 Applications

For a variety of small and medium-sized automation equipment and instruments, such as: Lithium equipment, 3C equipment, engraving machine, marking machine, cutting machine, laser phototypesetting, engraving machine, plotter, CNC machine tools, automatic assembly equipment. To match the application which need small noise and high speed equipment

4 Specifications

4.1 Electrical Specifications

Description	EST-556			
	Min	Typical	Max	Unit
Output Current(peak)	1.0	-	5.6	A
Input Voltage (DC)	15	24/36	50	VDC

Control Signal Input Current	6	10	16	mA
Control Signal Interface Electricity	4.5	5	28	Vdc
OC output Pull-Up voltage	5	-	24	Vdc
Ether-CAT communication frequency	-	100	-	MHz
Insulation Resistance	100			MΩ

4.2 Operating Environment

Cooling		Natural Cooling or Forced cooling
Environment	Condition	Far away from other heating device, Avoid dust, oil fog and corrosive gases, heavy humidity and strong vibration occasion, forbid flammable gases and conductive dust
	Temperature	-10℃ ~ +50℃
	Humidity	40 ~ 90%RH
	Vibration	5.9m/s ² MAX
Storage Environment		-20℃ ~ 60℃
Altitude		Less than 1000m
Weight		about 0.2KG

5 Mechanical Specifications

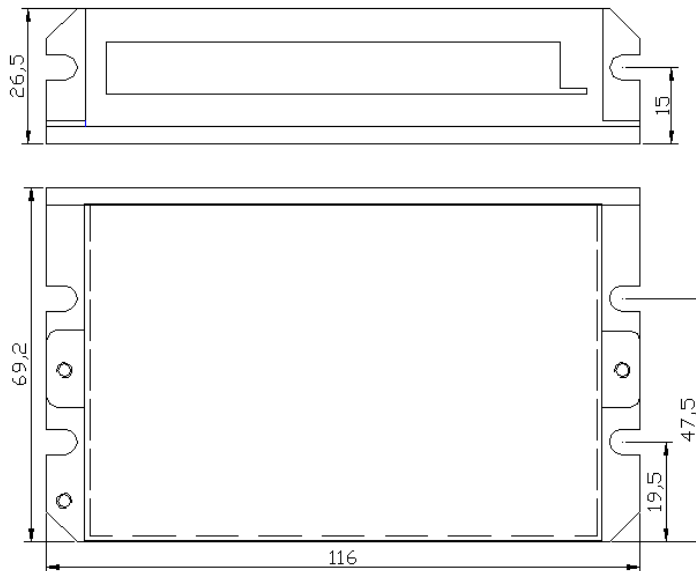

※Recommend side installation, better cooling effect, when design installation dimension, consider the terminal size and wiring!

Enhance Cooling method

A:The driver's reliable operating temperature is usually within 60 °C, the motor operating temperature is within

80 °C;

B: It is recommended to use the automatic half-flow mode, the current will be automatically reduced by half when the motor stops, so as to reduce the heating of the motor and the drive;

C: When installing the driver, please use the vertical side installation, so that the cooling teeth form a strong air convection; when necessary, install a fan where is close to the drive, forced cooling to ensure that the drive is in a reliable working temperature range

6 Connectors and Pin Assignment

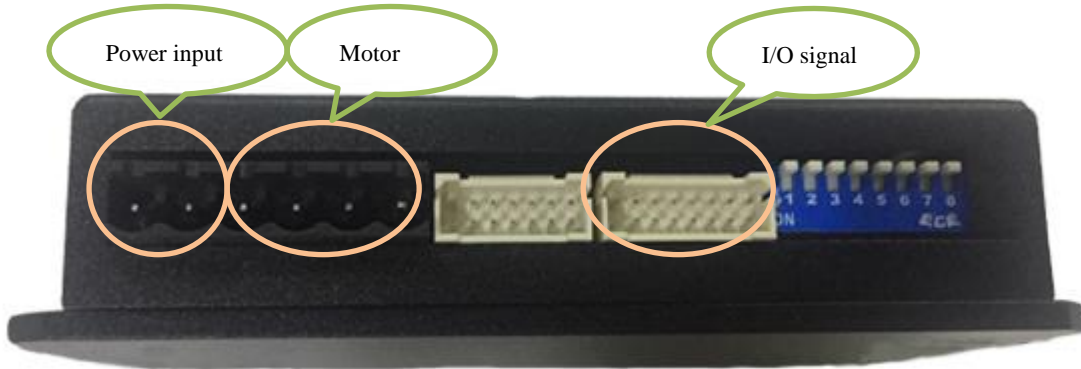

The EST-556 has three connectors: i/o connector, power and motor connector, and the CAT Communication Port

6.1 Control signals connector

Pin Function	Details
pl+	INEFFECTIVE
pl-	
dr+	
dr-	
in+	Low speed signal: in1, in2, in3 common positive input, 5-28VDC
in1	Low speed in1 negative input
in2	Low speed in2 negative input
in3	Low speed in3 negative input
ot-	Common negative OC emitter output, ot1, ot2, ot3 emitter OC output common terminal
ot1	ot1 emitter output, the Max pull-up voltage 24Vdc, the pull-up resistance 2KΩ, the Max output current 100mA
ot2	ot2 emitter output, the Max pull-up voltage 24Vdc, the pull-up resistance 2KΩ, the Max output current 100mA
ot3	ot3 emitter output, the Max pull-up voltage 24Vdc, the pull-up resistance 2KΩ, the Max output current 100mA

gnd	5V-
RS232-TX	
RS232-RX	
5V	5V+,current 50mA

6.2 Power and Motor

Pin	Definition	I/O	Description
1	A+	O	Motor Phase A+
2	A	O	Motor Phase A-
3	B+	O	Motor Phase B+
4	B-	O	Motor Phase B-
5	+VDC	I	15-50VDC,24V/36DC is recommended, leaving rooms for voltage fluctuation and back-EMF.
6	GND	GND	

Power supply voltage between the provisions of the normal work, EST series driver is best to use non-regulated DC power supply, can also use the transformer step-down + bridge rectifier + capacitor filter. However, take care that the peak value of the rectified voltage ripple does not exceed its maximum specified voltage. It is recommended that users use DC voltage lower than the maximum voltage to supply power and avoid the fluctuation of power grid beyond the working range of driver voltage.

If you are using a regulated switching power supply, be aware that the output current range of the switching power supply needs to be maximized.

Please note!

A:When wiring, pay attention to the positive and negative poles of the power supply.

B:Better use non-regulated power supply;

C:When use a non-regulated power supply, the power supply current output capacity should be greater than 60% of the drive setting current;

D:The use of regulated switching power supply, the output current of the power supply should be greater than or equal to the working current of the driver;

E:To reduce costs, two or three drives can share a power supply, but should ensure that the power supply is large enough.

6.3 EtherCAT Communication Port



Two RJ45 terminals

PIN	Signal	Function Description	
1	TX+	Ether CAT data sending positive port	EtherCAT IN (ECAT IN)
2	TX-	Ether CAT data sending negative port	
3	RX+	Ether CAT data receiving positive port	
4	NC	No connected	
5	NC	No connected	
6	RX-	Ether CAT data receiving negative port	
7	NC	Disconnect	
8	NC	Disconnect	
9	TX+	Ether CAT data sending positive	EtherCAT OUT (ECAT OUT)
10	TX-	Ether CAT data sending negative	
11	RX+	Ether CAT data receiving positive	
12	NC	No connected	
13	NC	No connected	
14	RX-	Ether CAT data receiving negative	
15	NC	No connected	
168	NC	No connected	

Note: The cable connecting EST-556 to PC must be a dedicated cable. Please check before use to avoid damage.

7 PA settings (DIP Switch Settings)



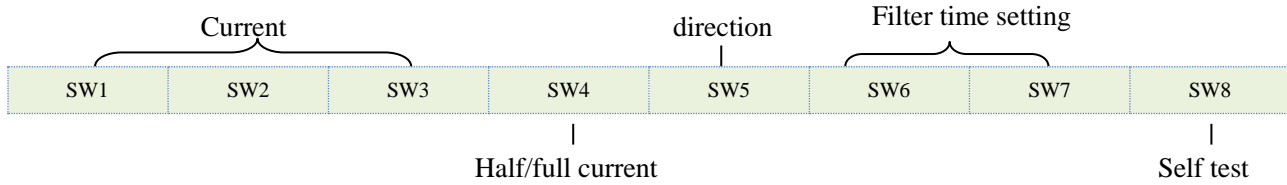

7.1 Current Table(dynamic current)

Current(peak)	Current(RMS)	SW1	SW2	SW3
Default[1.0A]	on	on	on	on
2.1A	1.5A	off	on	on
2.7A	1.9A	on	off	on
3.2A	2.3A	off	off	on
3.8A	2.7A	on	on	off
4.3A	3.1A	off	on	off
4.9A	3.5A	on	off	off
5.6A	4.0A	off	off	off

7.2 Standstill current setting

SW4 is used for this purpose. OFF meaning that the standstill current is software configured, and ON meaning that standstill current is set to be the same as the selected dynamic current. Generally, set the SW4 to be off , that can reduce the heating of motor

7.3 Motor direction setting

SW5 for setting the initial direction of motor
off=CCW, on=CW;

7.3 Smoothing filter time setting

Filter Sel	SW6	SW7	Description
Default 【0ms】	on	on	The more higher value for smoothing filter time setting, the more better performance for the Acc and Dec,but worse performance for the interpolation
2ms	off	on	
12ms	on	off	
25ms	off	off	

8 Stepper Motors

EST-556 can work with the following ECON technology's stepper motors:

8.1 Nema23 stepper motor

	ECN57-10	ECN57-20	ECN57-20BK (with brake)	ECN57-25
Step Angle (Degree)	1.8	1.8	1.8	1.8
Holding Torque (N.m)	1.1	2.0	2.0	2.5
Phase Current (A)	3.0	5	5	5.0
Phase Resistance (Ohm)	0.71	0.4	0.4	0.4
Phase Inductance (mH)	2.37	1.8	1.8	1.8
Inertia (g.cm2)	280	480	480	480
Weight (Kg)	0.72	1.2	1.8	1.0

8.2 Nema24 stepper motor

	ECN60-10	ECN60-16	ECN60-21	ECN60-31
Step Angle (Degree)	1.8	1.8	1.8	1.8
Holding Torque (N.m)	1.1	1.65	2.1	3.1
Phase Current (A)	2.8	2.8	2.8	2.8
Phase Resistance (Ohm)	0.75	0.9	1.2	1.5
Phase Inductance (mH)	2.0	3.6	4.6	6.8
Inertia (g.cm2)	275	300	570	840
Weight (Kg)	0.6	0.77	1.2	1.4

9 Wiring Diagrams

9.1 Interface

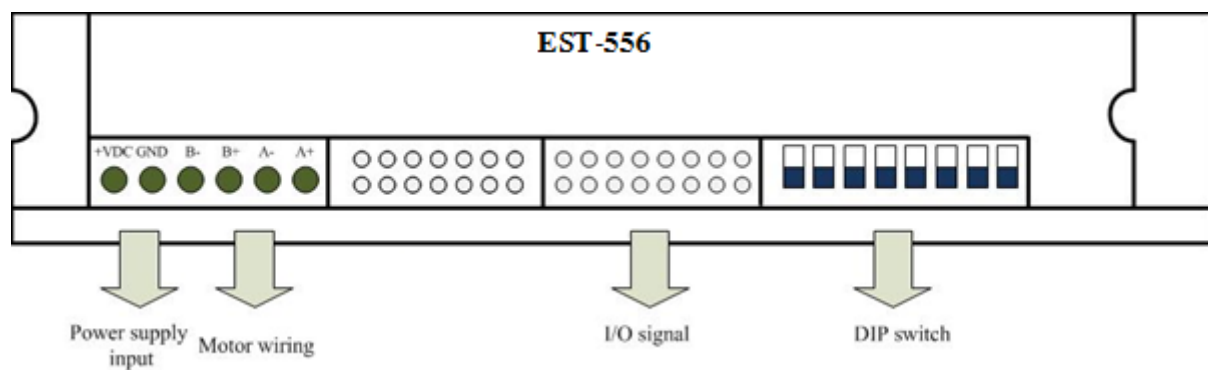

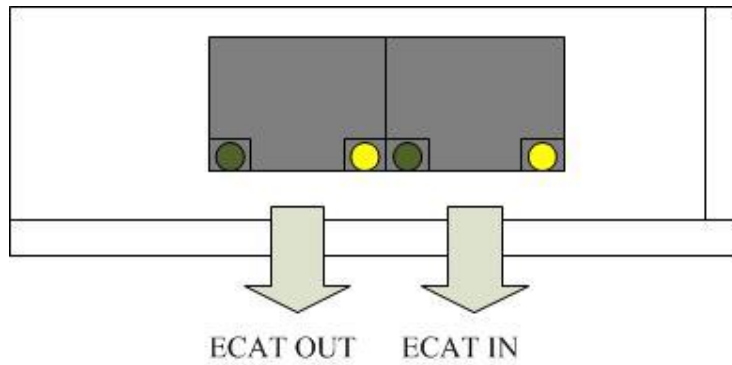

9.2 Diagram

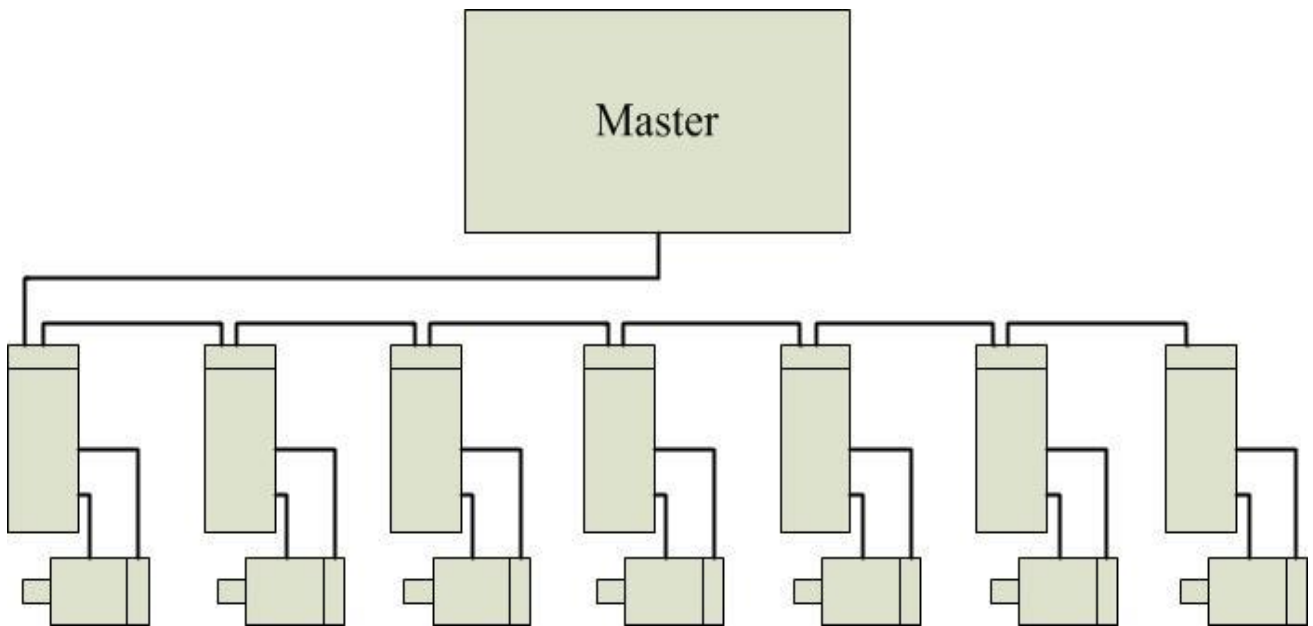

10 Protection Indications

The green indicator turns on when power-up. When drive protection is activated, the red LED blinks periodicity to indicate the error type.

Flashes Times	Red LED flash wave	Fault Description
1		over-current or phase short-circuit fault
2		over-voltage fault
3		under-voltage fault
7		over-error alarm
9		phase fault or current collecting fault

A:Over current or phase Short circuit protection

When a short circuit occurs or the internal drive over-current, the drive RED Led flashes 1 time, and repeat flashing within 3 seconds. At this point must discharge fault, re-power and reset.

B: Over-voltage protection

When input voltage is higher than 55V, the driver RED Led flashes twice, and flashes repeatedly within 3 seconds. At this point must discharge fault, re-power and reset.

Δ Note! Since the drive does not have the power supply reverse polarity protection function, therefore, before power on, make sure the positive and negative power supply wiring is correct. Reverse polarity will lead to burn the fuse in the drive!

11 Frequently Asked Questions

In the event that your drive doesn't operate properly, the first step is to identify whether the problem is electrical or mechanical in nature. The next step is to isolate the system component that is causing the problem. As part of this process you may have to disconnect the individual components that make up your system and verify that they operate independently. It is important to document each step in the troubleshooting process. You may need this documentation to refer back to at a later date, and these details will greatly assist our Technical Support staff in determining the problem should you need assistance.

Many of the problems that affect motion control systems can be traced to electrical noise, controller software errors, or mistake in wiring.

Problem Symptoms and Possible Causes

Problem	Possible Reason	Solution
Motor is not rotating	Power supply light is off	check power supply line, keep power supply normal
	motor shaft disabled	Pulse signal weak, increase signal current to 7-16mA
	Micro-step too small	select the suitable micro-step
	current setting is too small	Select the correct current
	drive protected	Reboot
	Enable signal too low	Pull up enable signal or disconnect
	no action to control signal	Check the power supply input
Wrong motor motion	Motor cable incorrect connect	Change any two cables of same phase(such as A+/A- change)
	Motor cable has breakage	Check and correct wiring connection
The drive In alarm	motor cable incorrect connect	Check wiring
	over-voltage or under-voltage	Check power supply
	motor or drive damaged	Replace a motor or drive
Position inaccurate	signal is interfered	Exclude interference
	Shield ground disconnect or bad connect	Reliable ground connection
	Motor cable has breakage	Check and correct wiring connection

	Wrong micro-step	Set correct micro-step
	Current small	Increase current
Motor stall when speed increase	Acceleration time is too short	Increase acceleration time
	Motor torque is too small	Select big torque motor
	Voltage is low or current is small	Suitable increase voltage and current

12 Warranty

Shenzhen ECON Technology Co., Ltd. warrants its products against defects in materials and workmanship for a period of 12 months from shipment out of factory. During the warranty period, ECON technology will either, at its option, repair or replace products which proved to be defective.

Exclusions

The above warranty does not extend to any product damaged by reasons of improper or inadequate handlings by customer, improper or inadequate customer wirings, unauthorized modification or misuse, or operation beyond the electrical specifications of the product and/or operation beyond environmental specifications for the product.

Obtaining Warranty Service

To obtain warranty service, a returned material authorization number (RMA) must be obtained from customer service at e-mail: technical01@hybridservo.com before returning product for service. Customer shall prepay shipping charges for products returned to ECON technology for warranty service, and ECON technology shall pay for return of products to customer.

Warranty Limitations

ECON technology makes no other warranty, either expressed or implied, with respect to the product. ECON technology specifically disclaims the implied warranties of merchantability and fitness for a particular purpose. Some jurisdictions do not allow limitations on how long and implied warranty lasts, so the above limitation or exclusion may not apply to you. However, any implied warranty of merchantability or fitness is limited to the 12-month duration of this written warranty.

Part 2 :EST-556EtherCATCommunication Protocol Specification

1. Introduction

EST-556 is a new released EtherCAT hybrid servo drive , which support CANopen over EtherCAT (CoE) control and CiA 402 operating modes ,including Profile Position (PP), Profile Velocity (PV), Homing (HM) and Cyclic Synchronous Position (CSP). This drive is compatible withmany EtherCAT controller/PLC ,such as Beckhoff, Omron, etc. its excellent performance can meet many applications with extra low noise,low heating and super smoothness.

2. Operation mode

Command input type	Variable	Operation mode
BUS command input	Address 6060H=1	PP mode
	Address 6060H=3	PV mode
	Address 6060H=6	HM mode
	Address 6060H=8	CSP mode

A: PP mode: profile position mode

B: PV mode: Profile velocity mode

C: HM mode: Homing mode

D: CSP mode: Cyclic synchronous position mode

2.1 Profile position mode(PP)

Profile Position control mode is general point to point operation, to move to target position of Target position (607Ah) object with receipt of Controlword (6040h) input, need to set Profile Position Mode at operation mode object (6060h). The Operation Mode Display object (6061h) is shown as Profile Position Mode.

2.1.1 Related objects

Data write/read	Object	Description	Value	Unit
RXPDO	6060h	Operation Mode	1	-
	6040h	Control word	User self-defined	-
	607Ah	Target Position	User self-defined	Unit
	6081h	Maximum speed	User self-defined	Unit/s
	6082h	Start /Stop speed	User self-defined	Unit/S^2
	6083h	Profile Acceleration	User self-defined	Unit/S^2
	6084h	Profile Deceleration	User self-defined	Unit/S^2
	6085h	Emergency stop deceleration, base on the value of 605Ah	User self-defined	Unit/S^2
	605Ah	Enable the deceleration of E-stop(5: enable; Others: disable)	User self-defined	-
	2000h	Revolution per round	User self-defined	pulse
TXPDO	6041h	Status word	Read only	-
	6064h	Actually position Feedback	Read only	Unit
	606Ch	Actual velocity feedback	Read only	Unit/s
	603Fh	Error code	Read only	-
	6061h	Operation mode display	Read only	-

2.1.2 Controlword and Status word

In PP Mode, the bits 4~6 of Controlword (6040h)

Bit	Value	Description
4(new position)	0 → 1	The motor run with the max speed(6081h) and Acc(6083h)/Dec(6084h) to latest target position(607Ah)
5((trigger immediately)	0	Trigger the new movement after the current movement is completed
	1	Interrupt the current movement immediately, and start the new movement
6 (absolutely /relatively)	0	Process target position(607Ah) as the absolutely position
	1	Process target position(607Ah) as the relatively position

2.1.3 Typical motion mode of bit 5 at PP mode

Bit 5	0	1
-------	---	---

Forward movement to updated target position with Acc/constant speed

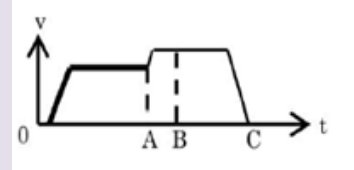
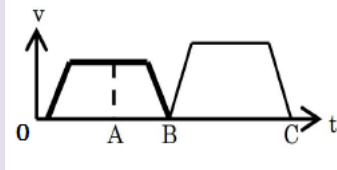

Forward movement to updated target position with Dec

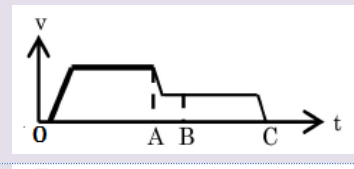
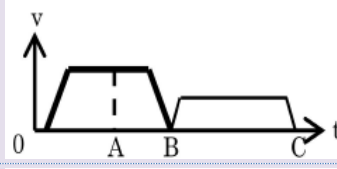

Backward movement to updated target position

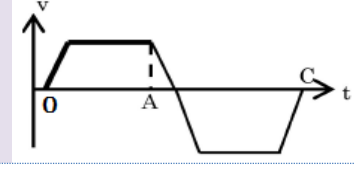
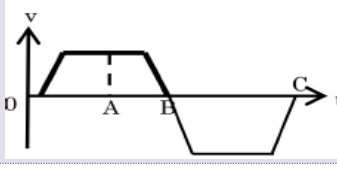

A:Command change time of master

B:Arrived time to the target position(before updated)

C:Arrived time to the target position(after updated)

2.1.4 The bit 8,10,12-15 of status word

Bit	Value	Description
8 (abnormal stop)	0	Normal movement
	1	Trigger by abnormal stop, motor will stop
10 (position reached)	0	Movement is continue
	1	target position reached
12 (new position response)	0	When current movement is completed or interruptable, can update new target position
	1	When current motion uncompleted/uninterruptable, it can not update new target position
14(parameters value for movement are 0)	0	Parameters for movement are effective, and all necessary parameters are not 0
	1	One of parameters(max speed-6081h, acceleration-6083h) and deceleration --6084h)must be 0
15 (Trigger response)	0	When current movement is not completed or not interruptable,can not update new target position
	1	When current movement is completed or interruptable, can update new target position

A: Bit8 abnormal stop is effective at the triggered status for hardware limit switch, deceleration stop and emergency stop

B:Bit 12 of Status word (6041h) will clear to 0 when the bit 5 of control word (6040h) is triggered and bit 4 of

(6040h) is invalid triggered (for example 6040h = 0x2F/4F), it can be interrupted

C: The logic of bit 5 and bit 12 is always reverse in PP mode.

2.2 Profile velocity mode(PV)

Profile velocity mode is a relatively simple operating mode via execution related command sending by EtherCAT master

Data write/read	Object	Description	Value	Unit
RXPDO	6060h	Operation Mode	1	-
	6040h	Control word	User self-defined	-
	60FFh	Target Position	User self-defined	Unit
	6083+00h	Profile Acceleration	User self-defined	Unit/S^2
	6084+00h	Profile Deceleration	User self-defined	Unit/S^2
TXPDO	6041h	Status word	Read only	-
	6064h	Actually position Feedback	Read only	Unit
	606Ch	Actual velocity feedback	Read only	Unit/s

2.2.1 Controlword and Status word

In PV Mode, bits 4~6of Control word (6040h) are not effective, the movement will be active by setting some movement parameters, including target velocity (60FFh), acceleration/deceleration (6083h/6084h).

Bit	Value	Description
8(quickly stop)	0	Quickly stop is disabled
	1	Quickly stop is enabled
10(speed reached)	0	The current speed has not reach to target speed
	1	The current speed reach to target speed
12 (speed is 0)	0	Speed is not 0 , the movement is not completed
	1	Speed is 0 or the speed is ready to be 0 with Dec

2.3 Cyclic synchronous position mode(CSP)

Cyclic Synchronous Position mode (CSP Mode) assigns target position to EST-556hybrid servo drives by Master's profile creation function through cyclic communication. Drives internally execute position/velocity control with receipt of target position in each cycle.

The supported synchronizing cycles are: 250us, 500us, 750us, 1000us, 2000us and 4000us.

2.3.1 Related objects

Data write/read	Object	Description	Value	Unit
	6060h	Operation Mode	1	-

RXPDO	6040h	Control word	User self-defined	-
	607Ah	Target Position	User self-defined	Unit
	60B0h	Maximum speed	User self-defined	Unit/s
	2000h	Revolution per round	User self-defined	pulse
TXPDO	6041h	Status word	Read only	-
	6064h	Actually position Feedback	Read only	Unit
	606Ch	Actual velocity feedback	Read only	Unit/s
	603Fh	Error code	Read only	-
	6061h	Operation mode display	Read only	-

2.4 Homing mode(HM)

Homing mode is the way of detecting the home point with command of Control word (6040h). 6060h is address for homing Mode enable/disable. And will execute the command once Mode of operation display (6061h) indicates Homing Mode.

2.4.1 Related objects

Data write/read	Object	Description	Value	Unit
RXPDO	6060h	Operation Mode	1	-
	6040h	Control word	User self-defined	-
	607Ah	Target Position	User self-defined	Unit
	6081h	Maximum speed	User self-defined	Unit/s
	6082h	Start /Stop speed	User self-defined	Unit/S ²
	6083h	Profile Acceleration	User self-defined	Unit/S ²
	6084h	Profile Deceleration	User self-defined	Unit/S ²
	6085h	Emergency stop deceleration, base on the value of 605Ah	User self-defined	Unit/S ²
	605Ah	Enable the deceleration of E-stop(5: enable; Others: disable)	User self-defined	-
	2000h	Revolution per round	User self-defined	pulse
TXPDO	6041h	Status word	Read only	-
	6064h	Actually position Feedback	Read only	Unit
	606Ch	Actual velocity feedback	Read only	Unit/s
	603Fh	Error code	Read only	-
	6061h	Operation mode display	Read only	-

2.4.2 The bits 4~6 of Control word (6040h)

Bit	Value	Description
4(new position)	0 → 1	The motor run with the max speed(6081h) and Acc(6083h)/Dec(6084h) to latest target position(607Ah)
5((trigger immediately)	0	Trigger the new movement after the current movement is completed
	1	Interrupt the current movement immediately, and start the new movement
6 (absolutely /relatively)	0	Process target position(607Ah) as the absolutely position
	1	Process target position(607Ah) as the relatively position

2.4.3 The bit 8,10,12-15 of status word

Bit	Value	Description
8 (abnormal stop)	0	Normal movement
	1	Trigger by abnormal stop, motor will stop
10 (position reached)	0	Movement is continue
	1	target position reached
12 (new position response)	0	When current movement is completed or interruptable ,can update new target position
	1	When current motion uncompleted/uninterruptable, it can not update new target position
14(parameters value for movement are 0)	0	Parameters for movement are effective, and all necessary parameters are not 0
	1	One of parameters(max speed-6081h, acceleration-6083h) and deceleration --6084h)must be 0
15 (Trigger response)	0	When current movement is not completed or not interruptable,can not update new target position
	1	When current movement is completed or interruptable, can update new target position

A: Bit8 abnormal stop is effective at the triggered status for hardware limit switch, deceleration stop and emergency stop

B:Bit 12 of Status word (6041h) will clear to 0 when the bit 5 of control word (6040h) is triggered and bit 4 of (6040h) is invalid triggered (for example 6040h = 0x2F/4F), it can be interrupted

C: The logic of bit 5 and bit 12 is always reverse in PP mode.

3. Input and output

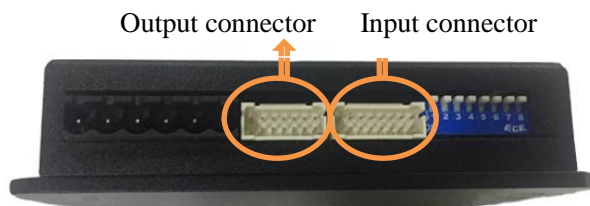

3.1 Input configuration

The IN1~IN3 are single end input ports(The power supply from host Controller/PLC/motion Control card should be 12-24VDC, current $\geq 100\text{mA}$), pl+,pl-,dr+,dr- are high speed differential pulse input ports.

Address	Definition		Default value	Range	Description
2152+01	Input 1	R/W/S	1	0—32768	1: homing 2: limit- 4: limit+
2152+02	Input 2	R/W/S	2	0—32768	1: homing 2: limit- 4: limit+
2152+03	Input 3	R/W/S	4	0—32768	1: homing 2: limit- 4: limit+
2152+04	Input 4	R/W/S	8	0—32768	1: homing 2: limit- 4: limit+
2152+05	Input 5	R/W/S	0	0—32768	1: homing 2: limit- 4: limit+
2153+01	Filter time for Input1	R/W/S	20	1—60000	Unit: 50us
2153+02	Filter time for Input2	R/W/S	20	1—60000	Unit: 50us
2153+03	Filter time for Input3	R/W/S	20	1—60000	Unit: 50us
2153+04	Filter time for Input4	R/W/S	20	1—60000	Unit: 50us
2153+05	Filter time for Input5	R/W/S	20	1—60000	Unit: 50us

2154+00	Logic configuration for inputs	R/W/S	0	0/1	0: Positive logic 1: negative logic bit0: input1 polarity setting bit1: input2 polarity setting bit2: input3 polarity setting bit3: input4 polarity setting bit4: input5 polarity setting
2155+00	Level configuration for inputs	R	0	0/1	0: Low level 1: High level bit0: input1 polarity setting bit1: input2 polarity setting bit2: input3 polarity setting bit3: input4 polarity setting bit4: input5 polarity setting

IO Status display

Address	Definition			Description
60FD+00	Input status	R		bit0: limit- bit1: limit+ bit2: homing

3.2 Output configuration

A:The power supply for outputs is 12-24VDC, and if power supply is wrong wiring, it is a risk to burnt the drive

B:It is OC output with the maximum capacity of 50mA/25V, it is recommended to connect a resistor to power supply(1K Ohm for 12VDC ,2K Ohm for 24VDC)

C:If the output is a relay, it is recommended to connect a freewheel diode with inverse parallel connection to relay for protection the drive

Address	Definition		Default value	Range	Description
2005+01	Output1	R/W/S	1	1—4	bit0: Alarm output bit1: Ready output Bit2: Pend output
2005+02	Output 2	R/W/S	1	1—4	bit0: Alarm output bit1: Ready output Bit2: Pend output

2008+00	Output level	R/W/S	0	0/1	0: Low level 1: High level bit0 :out1 bit1: out2
---------	--------------	-------	---	-----	---

3.3 Related node ID

The master can scan the node address automatically ,and it also can be set by manual

3.3.1 DIP switch setting

When the 2151h value is 0,the user can set the slave address by DIP switch(it is effective only after restarting drive)

3.3.2 Reading the ID alias of ESC

The EtherCAT master can configure ID alias to the EEPROM 0004h of ESC, when the 2051h is 0, and the address setting via DIP switches is 0, the value at address 0004h will be the ID alias of the slave after the power supply restarted.

3.3.3 Setting the ID alias via object dictionary

If the 2151h is 1,the value of 2150h will be the ID alias after the power supply. restarted.

Address	Definition		Default value	Range	Description
2150+00	Slave address	R/W/S	1	1—65535	Slave address
2151+00	Salve address resource	R/W/S	0	0~2	0: From DIP switch, when the DIP setting is 0, it is from EEPROM. 1: From 2150h

3.4 Motor rotation direction setting

The motor rotation direction can be set by command from master

Address	Definition		Default value	Range	Description
2051+00	Motor rotation direction	R/W/S	0	0/1	0: no change for motor rotation direction 1: reversed motor rotation direction

3.5 Pulse/Revolution setting

Address	Definition		Default value	Range	Description
2001+00	Pulse/Revolution	R/W/S	50000	200—51200	Pulse for per revolution

4. Parameters

4.1 Parameter saving

The master save the parameters to EEPROM via 0x1010-04 written. When the drive detect the value of 0x1010-04 from master is 0x65766173, the drive will save parameters to EEPROM.

Note! During the EEPROM written operation , please don't cut off power supply of drive , otherwise cause the wrong data written

4.2 Parameter reset

The master reset the parameters to default value via 0x1010-04 written. When the drive detect the value of 0x1010-04 from master is 0x64616f6c,all parameter will be reset to default value .

4.3 Parameters list

4.3.1 General parameter list

Address	Definition		Default value	Range	Description
2000+00	Peak current	R/W/S	3200	1 to the max current	Output current(mA)。
2001+00	Pulse/revolution	R/W/S	50000	200—51200	Pulse for per revolution (pulse)
2002+00	Stand-by time	R/W/S	500	100—10000	Unit: ms
2005+01	Output1	R/W/S	1	1—4	bit0: Alarm output bit1: Ready output Bit2: Pend output
2005+02	Output 2	R/W/S	1	1—4	bit0: Alarm output bit1: Ready output Bit2: Pend output
2008+00	Output level	R/W/S	0	0/1	0: Low level 1: High level bit0 :out1 t1: out2
2009+00	Pulse filter time enable/disable	R/W/S	0	0/1	0: Disable 1: Enable
2010+02	Filter time	R/W/S	1000	50—25600	Unit:us

2013+00	Current loop KP,KI auto tuning enable/disable	R/W/S	1	0/1	Auto tuning the Current loop KP,KI when power up 0: disable 1: enable
2015+00	Current Kp	R/W/S	1000	200—32767	When the 2013+00 is 1(enable), this parameter read only
2016+00	Current Ki	R/W/S	200	0—32767	When the 2016+00 is 1(enable), this parameter read only
2017+00	Current Kc	R/W/S	100	80—300	Read only
2020+00	Motor resistor	R/W/S	1000	1—20000	Unit: mOhms
2021+00	Motor inductance	R/W/S	1	1—6000	Unit: uH
2024+00	Open/closed mode	R/W/S	2	0~2	1: open loop mode 2: closed loop mode
2025+00	Control mode	R/W/S	5	0—10	0: DIP switch 1: Lead2: PM 3: FOC 4: self- test 5: CL
2026+00	Current for shaft locking	R/W/S	50	0—100	Unit:%, Effective at open loop mode only
2029+00	Encoder resolution	R/W/S	1000	200—60000	p/r
2030+00	Position following error	R/W/S	1000	1—60000	pulse
2039+00	Pulse amount H	R	0	0~65535	The received pulse amount H (16bit)
2040+00	Pulse amount L	R/W	0	0~65535	The received pulse amount 16bit write: write 1 to clear counter
2041+00	Encoder feedback amount H	R	0	0~65535	The received encoder feedback pulse amount H(16bit)
2042+00	Encoder feedback amount L	R	0	0~65535	The received encoder feedback pulse amount L(16bit) write: write 1 to clear counter
2051+00	Motor rotation direction	R/W/S	0	0/1	0:no change for the rotation direction 1:reversed rotation direction
2053+00	Pend output	R/W/S	0	0~1	0:low level 1: high level

2056+00	Fault detecting selection	R/W/S	0xc3	0—0xffff	
2057+00	Fault clear enable/disable	R/W/S	0	0/1	0: Disable 1: Enable
2058+00	Current soft-start time for shaft enable	R/W/S	1	0—10000	For reducing the vibration when power up or motor shaft enable Unit: 50us
2083+00	Shaft right left wiggle when power up enable/disable	R/W/S	0	0/1	0: Disable 1: Enable
2137+00	Position loop KP	R/W/S	120	0~150	-
2138+00	Position loop KI	R/W/S	50	0~150	-
2139+00	Position loop KVFF	R/W/S	70	0~150	-
2140+00	Speed loop KP	R/W/S	60	0~150	-
2150+00	Slave ID	R/W/S	1	1—65535	Slave address
2151+00	Slave ID resource	R/W/S	0	0~2	0:from DIP switch , when DIP switch is 0,it is from EEPROM. 1: from2150h
2152+01	Input 1	R/W/S	1	0—32768	1: homing 2: limit- 4: limit+
2152+02	Input 2	R/W/S	2	0—32768	1: homing 2: limit-
2152+03	Input 3	R/W/S	4	0—32768	1: homing 2: limit-
2152+04	Input 4	R/W/S	8	0—32768	1: homing 2: limit-
2152+05	Input 5	R/W/S	0	0—32768	1: homing 2: limit-
2153+01	Filter time for Input1	R/W/S	20	1—60000	Unit: 50us
2153+02	Filter time for Input2	R/W/S	20	1—60000	Unit: 50us
2153+03	Filter time for Input3	R/W/S	20	1—60000	Unit: 50us
2153+04	Filter time for Input4	R/W/S	20	1—60000	Unit: 50us
2153+05	Filter time for Input5	R/W/S	20	1—60000	Unit: 50us

2154+00	Logic configuration for inputs	R/W/S	0	0/1	0: Positive logic 1: negative logic bit0:input1 polarity setting bit1: input2 polarity setting bit2: input3 polarity setting
2155+00	Level configuration for inputs	R	0	0/1	0: Low level 1: High level bit0: input1 polarity setting bit1: input2 polarity setting bit2: input3 polarity setting bit3: input4 polarity setting bit4: input5 polarity setting
2093+00	Record for fault clear	R/W			

4.3.2 Operation mode control parameter list

Address	Definition		Description
6040+00	Control word	R/W	Control word
6041+00	Status word	R	Status word
6060+00	Operation mode	RW	1—PP mode 3—PV mode 6—HM mode 8-CSP mode
6061+00	Mode display	R	Display the operation mode
6062+00	Command position	R	Display the motor command position
6064+00	Actual position	R	Display the motor actual position
606B+00	Command speed	R	Display motor command speed
606C+00	Actual speed	R/W	Display the motor actual speed Unit: RPM
607A+00	Target position	R/W	The target position at PP mode, if the control word setting for movement start, it will be changed to valid command position
607C+00	Homing offset	R/W	Homing offset
6081+00	Trapezoidal speed-	R/W	The max trapezoidal speed at PP mode

6082+00	Start-stop speed	R/W	The start and stop speed at PP mode
6083+00	Trapezoidal Acc	R/W	Trapezoidal Acc
6084+00	Trapezoidal Dec	R/W	Trapezoidal Dec
6085+00	Dec for E-stop	R/W	Dec for E-stop, it is enabled or disabled depend on the value of 605A
6098+00	Homing research mode	R/W	Homing research mode
6099+01	Homing research speed	R/W	Speed for researching limit switch
6099+02	Homing research speed	R/W	Speed for researching homing
609A+00	Homing research Acc	R/W	Acc of Homing research
60F4+00	Position following error	R	Position following error
60FD+00	Input status	R	bit0: limit-, bit1: limit+, bit2: homing
60FF+00	Target speed	R/W	The max speed at PV mode

5. Basic Information Of EtherCAT

5.1 EtherCAT Data Frame Structure

EtherCAT transmit the data with the network data frame; the fixed frame type is 0x88A4. It includes two bytes of EtherCAT frame header and 44~1498 bytes of EtherCAT data. The EtherCAT data field consists of one or some EtherCAT sub messages, each message is corresponding to a storage area of the slave station.

Frame structure	Definition
Target address	MAC address of Receiver
Source address	MAC address of Sender
EtherCAT frame header: data length	EtherCAT the total length of all sub messages in the data field
EtherCAT frame header :type	1: communication with slave stations; others are reserved
FCS	The Frame check

5.2 Synchronous Mode

5.2.1 Random running mode

At this mode, the drive adopt asynchronous mode to process the processing data from master, it is suitable for asynchronous operation mode only, such as HM mode, PP mode.

5.2.2 Distributed clock synchronization mode

After the master sending the processing data , the slave station receive and read the processing data immediately, at the same time ,it wait the Synchronous signal to trigger the processing data and effect to drive
The processing data must reach drive earlier than SYNC0 T1,and the drive must compete all Analysis of data and related control algorithm. after receiving SYNC0,drive send the control command immediately. This mode is very good for data Synchronization

5.2.3 EtherCAT state machine

EtherCAT state machine, commonly called as "communication state machine.it mainly manage the communication between master and slave .this communication function includes the communication for mail and processing data.

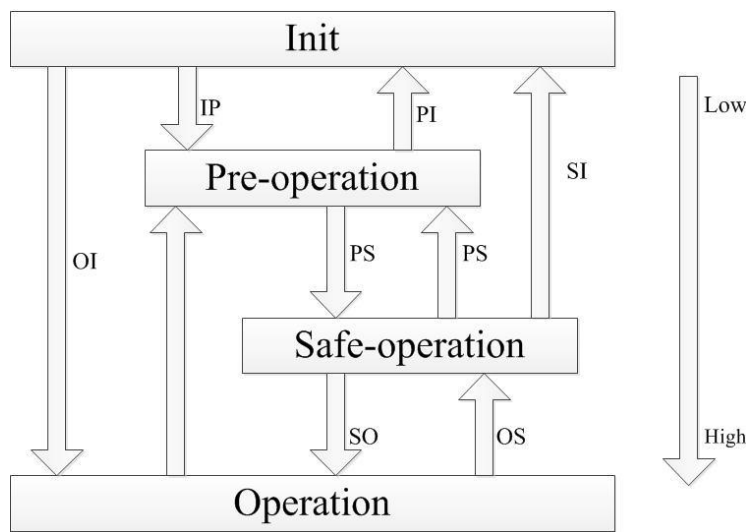

EtherCAT state machine transmission flow chart

The transmission of the EtherCAT state machine features:

- A:**From initialization to operation, it must follow the sequence (low--high) strictly: you must switch from low to high, such as initialization→pre-operation→Safe-operation→operation
- B:**From high to low transmission, it can be skipped .
- C:**The master is the sender for all state transmission, the slave must response all request from master
- D:**If the request from master is failed ,the slave will feedback error to master

	Communicationfunction
In it	Communication between master and slave stations
Pre-Operation	Mail communication is effective, and no processing data communication, means SDO function is effective
Safe-Operation	Mail communication and processing data objects sending are effective, means SDO and TXPDO are effective
Operation	Mail communication, processing data receiving and are is effective, means SDO, RXPDO and TXPDO are effective

5.3 COE

COE is similar as CANopen DS301, but basic on CANopen DS301, the COE has some changes and extension, the main difference as below chart

Items	COE	DS301
Fieldbus	EtherCAT	CAN
Message structure	Standard Ethernet	CAN 2.0A standard
SDO data collection	SM mailbox data area	CAN message
PDO data collection	SM processing data area	CAN message
The length for Each PDO mapping	Maximum 32 bytes	Maximum 8 bytes
Communication state machine	0x120/0x130 register	NMT (network management tool)
Identification of communication	Synchronization management (SM)	COB-ID (object dictionary identification)

5.3.1 Service data object (SDO)

EST-556 hybrid servo drive supports SDO function, the EtherCAT master can write/read the object dictionary of drive, and configure, monitor, control the drive by SDO.

The SDO is the user/server mode, the master corresponds to the user in the SDO operation, and

The drive is a server, all of transmission/command must be from master to user.

At the CANopen DS301 mode, the SDO protocol can transmit 8 bytes one time in order to match the data length of CAN packets. At the COE enhancement mode, it expands the payload data only, and doesn't change the protocol header. In this way, the SDO can use the larger mailbox, and improve the efficiency of data transmission.

5.3.2 SDO protocol and message format

Here are two SDO services supported by EST-556 hybrid servo drive

A: Fast transmission service: it is the same as CANopen DS301, use 8 bytes only to transmit 4 bytes of valid data

B: Conventional transmission service: the max bytes of transmission data depend on the capacity of mailbox manager.

SDO download service format as below chart

Bits	48	16	64	depend on the capacity of mail box manager.
Mapping content	Data header of mail box	Data header of COE	Standard SDO data	Expansive data



I:quantity mark E:transmission type SIZE :number of bytes

C:completed visit CCS: command code

The details table for transmission requested service data of SDO downloading

Data area	Bytes	Bit	Definition	Description
Mail header	2	16	Length n	n≥0x0A,COE command and length of SDO data
	2	16	Address	Data resource address
	1	0~5	Channel	Reserved
		6~7	Priority grade	0: lowest priority
		0~3	Type	3: COE
COE command	2	4~7	Reserved	
		0~8	PDO code	0
		9~11	Reserved	
SDO data	1(control byte)	12~15	Service type	2: SDO request
		0	Quantity mark	0: Not set; 1: Set byte of transmission
		1	Transmission	0:conventional/segment
		2~3	Byte transmission	0:conventional/segment transmission invalid; others: number of byte transmission
	4	Completed visit	0: incomplete visit; 1: complete visit	
	5~7	Command code	0:segment download request 1: download request	
	2	16	Index	Object dictionary index
1	8	Sub-index	Object dictionary sub-index	

	4	32	Data	Fast transmission: specified object dictionary data Conventional transmission: total bytes of object dictionary
	n-10		Extended data	Conventional transmission for extended data

5.3.3 Suspend SDO transmission

If it occurs error for data analysis during SDO transmission, the request for suspending SDO transmission can be sent to master, and receiving the request, SDO transmission is suspended immediately

Suspend SDO transmission chart

Data area	Bytes	Bit	Definition	Description
Mail header	2	16	Length n	$n \geq 0x0A$, COE command and length of SDO data
	2	16	Address	Data resource address
		0~5	Channel	Reserved
	1	6~7	Priority grade	0: lowest priority
	1	0~3	Type	3: COE
		4~7	Reserved	
COE command	2	0~8	PDO code	0
		9~11	Reserved	
		12~15	Service type	2: SDO request
SDO data	1 (control byte)	0	Quantity mark	0
		1	Transmission	0: conventional/segment
		2~3	Byte transmission	0
		4	Reserved	
		5~7	Command code	4: Terminate SDO transmission request
	2	16	Index	Object dictionary index
	1	8	Sub-index	Object dictionary sub-index
4	32	suspend code	Details refer to the suspend code chart	

Suspend code chart

Termination code	Meanings
0x05040000	SDO transmission timeout
0x05040001	Command code is invalid or unknown
0x05040005	Memory overflow

0x06010000	An attempt to manipulate objects that do not support access
0x06010001	An object that attempts to write only properties
0x06010002	An object that attempts to write a read-only property
0x06020000	The object to access does not exist
0x06040041	Object cannot be mapped to PDO
0x06040042	The length of the PDO mapping exceeds the prescribed length
0x06090011	The object sub-index does not exist
0x06090031	The input value exceeds the max value and it's set to the max value automatically
0x06090032	The input value exceeds the min value and it's set to the min value automatically
0x08000000	General error
0x08000020	Unsupported transmission/save operation
0x08000021	Invalid save operation

5.4 processing data object

PDO generally used for real time data updating :it includes RXPDO and TXPDO.RXPDO is that master send the data to slave station , and TXPDO is reversed

5.4.1 PDO mapping

The mapping objects can be real time transmission via PDO mapping.

E5-CAT supports 4groups RXPDO and 2 groups TXPDO for data transmission at the same time. Each PDO object mapping to 8bytes object dictionary(the max length is 32bytes).

The PDO mapping format

Bit	31~16	15~8	7~1
Content	Index of mapped object	Sub-index of mapped object	Bit length (hexadecimal form)
Example	6040h	00h	10h (length:16bits)

The default PDO mapping(same as XML file)

PDO mapping object index	PDO object sub-index	Mapping content	Mapping content details			Mapping content definition
			Index	Sub-index	Bit length	
	01h	60400010h	6040h	00h	10h (16bits)	Control word

RXPDO1 (1600h)	02h	607A0020h	607Ah	00h	20h (32bits)	Target position
	03h	60B00020h	60B0h	00h	20h (32bits)	Position offset
	04h	60B80010h	60B8h	00h	10h (16bits)	Probe function
RXPDO2 (1601h)	01h	60400010h	6040h	00h	10h (16bits)	Control word
	02h	607A0020h	607Ah	00h	20h (32bits)	Target position
	03h	60810020h	6081h	00h	20h (32bits)	Max. speed
	04h	60830020h	6083h	00h	20h (32bits)	Acceleration
	05h	60840020h	6084h	00h	20h (32bits)	Deceleration
	06h	60600008h	6060h	00h	08h (8bits)	Operation mode
RXPDO3 (1602h)	01h	60400010h	6040h	00h	10h (16bits)	Control word
	02h	60FF0020h	60FFh	00h	20h (32bits)	Target speed
	03h	60830020h	6083h	00h	20h (32bits)	Acceleration
	04h	60840020h	6084h	00h	20h (32bits)	Deceleration
	06h	60600008h	6060h	00h	08h (8bits)	Operation mode
RXPDO4 (1603h)	01h	60400010h	6040h	00h	10h (16bits)	Control word
	02h	60980008h	6098h	00h	08h (8bits)	Homing mode
	03h	60990120h	6099h	01h	20h (32bits)	Homing speed (fast)
	04h	60990220h	6099h	02h	20h (32bits)	Homing speed(slow)
	05h	609A0020h	609Ah	00h	20h (32bits)	Homing acceleration/ deceleration
	06h	607C0020h	607Ch	00h	20h (32bits)	Homing offset
	07h	60600008h	6060h	00h	08h (8bits)	Operation mode
TXPDO1 (1A00h)	02h	60410010h	6041h	00h	10h (16bits)	Status word
	03h	60610008h	6061h	00h	08h (8bits)	Operation mode display
	04h	60640020h	6064h	00h	20h (32bits)	Actual position
	05h	60B90008h	60B9h	00h	10h (16bits)	Probe status
	06h	60BA0020h	60BAh	00h	20h (32bits)	Probe 1 rising edge position
	07h	60FD0020h	60FDh	00h	20h (32bits)	Digital input status
TXPDO2	No default mapping					

5.4.2 PDO dynamical mapping

COE use PDO specified object(1C12h/1C13h) to configure PDO mapping object(1600h~1603h/1A00h~1A01h) to the PDO object synchronization manager (synchronization manager 2/3)

PDO specified object

Index	Sub-index	Range	Data type	Access property
RXPDO Specified object (1C12h)	00h	0~4	U8*1)	RO
	01h	1600h~1603h	U16	RW
	02h		U16	RW
	03h		U16	RW
	04h		U16	RW
TXPDO Specified object (1C13h)	00h	0~2	U8	RO
	01h	1A00h~1A01h	U16	RW
	02h		U16	RW

5.4.3 The difference of PDO and SDO

Contrast terms	PDO	SDO
Communication ability	The Maxis 64 bytes	General 4 bytes (fast transmission)
Efficiency	high	low
Priority level	high	low
Real-time performance	Real-time(synchronous mode)	Non-real-time
Transmission initiative	Active transmission	Passive transmission
Object dictionary visit	Indirect visit	Direct visit
	Visit PDO mapping object	Visit arbitrary objects
synchronism	synchronization/synchronization	Synchronization
Application	Real-time data transmission	Configure PDO mapping、 parameter setting

Contact us:

Shenzhen ECON Technology Co.,Ltd

Add: 2F, Building B, Jintai, Industrial, Park, Hangcheng Avenue, Gushu Village, Xixiang Street, Bao'an Area, Shenzhen City, Guangdong Province, China

Tel: +86 136 2096 1024

Sales: enquiry@hybridservo.com

Technical support: technical01@hybridservo.com